



ScFFin

Software Enabled Fiber Optic Multisensing Network Brochure v1.0

02/2026



Funded by
the European Union

Project Funded by the European Union. Views and opinions expressed are however those of the author(s) only and do not necessarily reflect those of the European Union or HADEA. Neither the European Union nor the granting authority can be held responsible for them.

ABOUT THE PROJECT

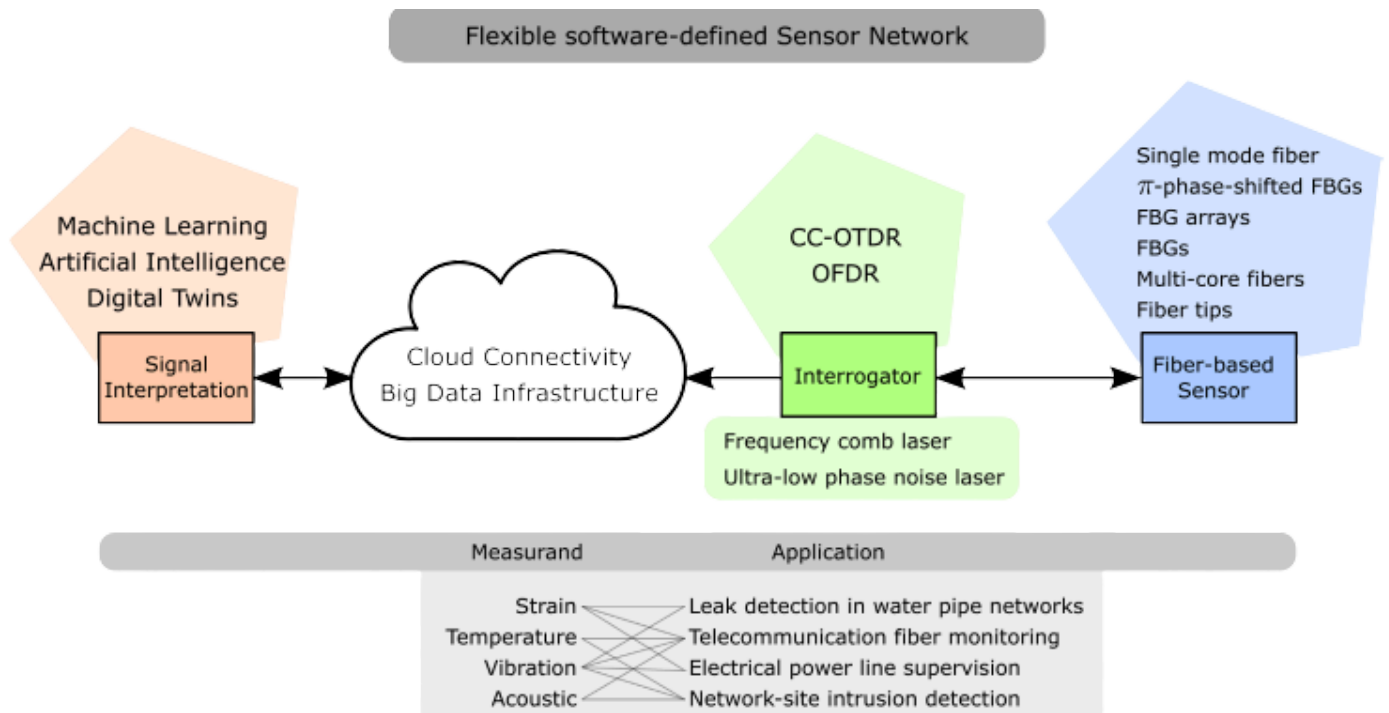

SoFiN aims to unlock the full potential of fiber-optic sensing by transforming today's niche solutions into an adaptive, modular, and software-defined sensing platform. The project leverages both existing fiber infrastructure and dedicated sensing fibers, e.g. Fiber Bragg Grating (FBG) -based, to perform distributed sensing.

Challenge #1: Ability to monitor complex environments

Challenge #2: System resource efficiency

Challenge #3: Avoid specific solutions by a flexible, software-controlled sensor platform

Challenge #4: Advanced signal processing and cloud data analytics

By combining flexible fiber-sensor concepts with cloud-based control, advanced signal processing, machine-learning methods, and digital-twin technologies, SoFiN develops a scalable, reconfigurable, and high-performance sensing platform supporting continuous environmental monitoring and optimization. The SoFiN platform will be validated over three use cases.



Funded by
the European Union

Project Funded by the European Union. Views and opinions expressed are however those of the author(s) only and do not necessarily reflect those of the European Union or HADEA. Neither the European Union nor the granting authority can be held responsible for them.

OBJECTIVES



Objective 1: Develop an adaptive, modular and highly integrated photonic multisensing system, capable for various sensing applications in a sensor network.

The goal is to develop a flexible sensor platform that can be used for various fiber-based sensing applications. Therefore, an integrated and energy efficient interrogator hardware setup is developed, which can be easily adapted by software to different sensing needs.

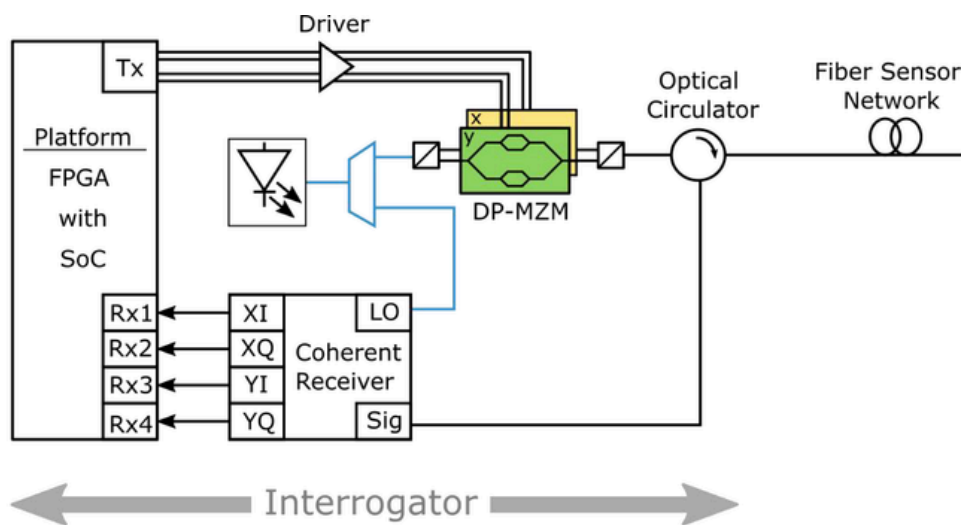

Objective 2: Establish new types of digital signal processing and cloud connection of the sensor system.

The objective is to develop novel signal processing concepts to improve sensing performance and integration of the sensor system into a cloud-based monitoring system.



Objective 3: Validation and Demonstration under context of end-user needs.

The system will be validated through lab tests and applied to three representative use cases to assess real-world performance. Tests will include different interrogation formats with standard fibers and FBG arrays. Demonstrations focus on distributed sensing for critical infrastructure: monitoring temperature in power cables, detecting perimeter events in telecommunication networks, and identifying leaks or manipulations in water supply networks.



USE CASE #1: Telecom Infrastructure Supervision

In this use case the optical fiber network of a telecommunication operator will be utilized as a sensor element and will provide information on external impacts threatening the fiber infrastructure, like fire, stress, heavy machinery in the perimeter of fiber cables that could rise the risk for fiber damage, or on the unexpected presence of people in facilities.



USE CASE #2: Water Supply Network Supervision



Distributed Acoustic Sensing (DAS) will be used in combination with FBG sensing to detect water leaks in an early stage. Thus, inspection-based supervision can be avoided and permanent supervision will be facilitated.

USE CASE #3: High Voltage Power Cables Monitoring

In this case study, the innovations from SoFiN will be applied to the monitoring of powerlines. This will involve using distributed temperature sensing and distributed acoustic sensing to gather comprehensive data.

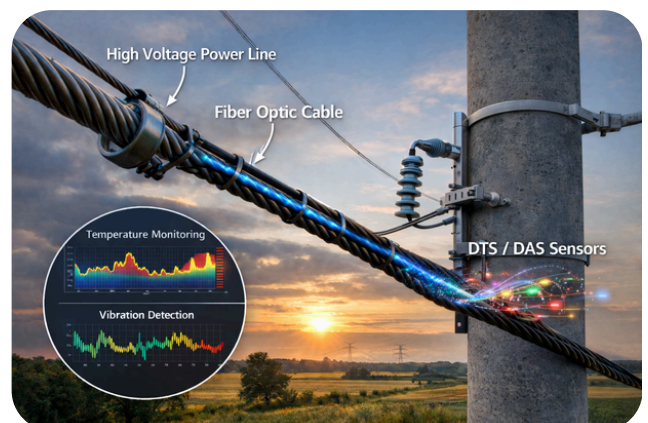

TECHNOLOGY BREAKTHROUGH

RESULT #1: High performance lasers

A novel ultra-low-noise single-wavelength laser was designed, built, and experimentally validated.

NKT's proprietary laser technology was successfully integrated with a silicon-nitride dual-ring microresonator to generate a dark-soliton frequency comb.



RESULT #2: Novel approach for PM - π - FBG based multi-modal sensing

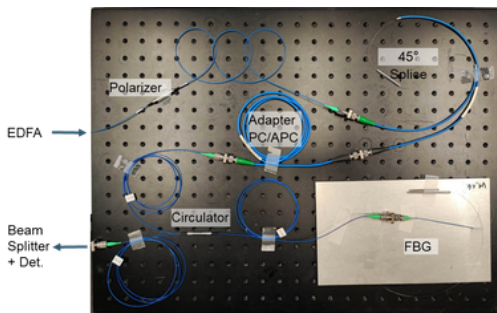

The testbed to validate the novel approach for the separation of temperature and strain based on the PM- π -FBG has been developed and initial results have been obtained.

RESULT #3: Digital Twin Technology for the fiber sensing

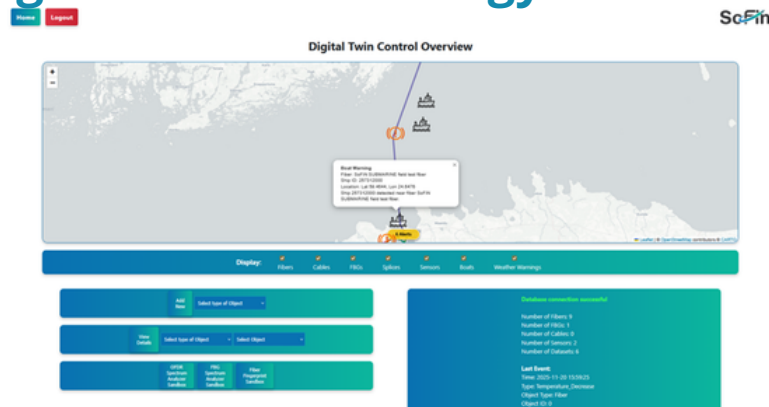

A modular Digital Twin was developed to represent each fiber sensor with real-time data updates. It combines structured system descriptions, advanced applications (e.g. anomaly detection, simulations, and alerts), and historical tracking to monitor performance, detect faults, and support long-term network optimization.



Funded by
the European Union

Project Funded by the European Union. Views and opinions expressed are however those of the author(s) only and do not necessarily reflect those of the European Union or HADEA. Neither the European Union nor the granting authority can be held responsible for them.

TECHNOLOGY BREAKTHROUGH

RESULT #4: Integrated Sensor Platform development

A highly configurable interrogator for combined time- and frequency-domain sensing based on coherent correlation OTDR has been realized. The demonstrator integrates a high-performance laser, a highly integrated photonic transceiver chip, and an FPGA-based signal processing chain.



RESULT #5: Physics based synthetic data generation for ML algorithms & event classification

A physics-based modeling approach was developed to generate synthetic training data generating both phase and amplitude responses under dynamic conditions, where localized temperature or strain variations are induced by external perturbations. Furthermore, the software for event classification and cloud interaction was implemented.

RESULT #6: Cloud Platform development

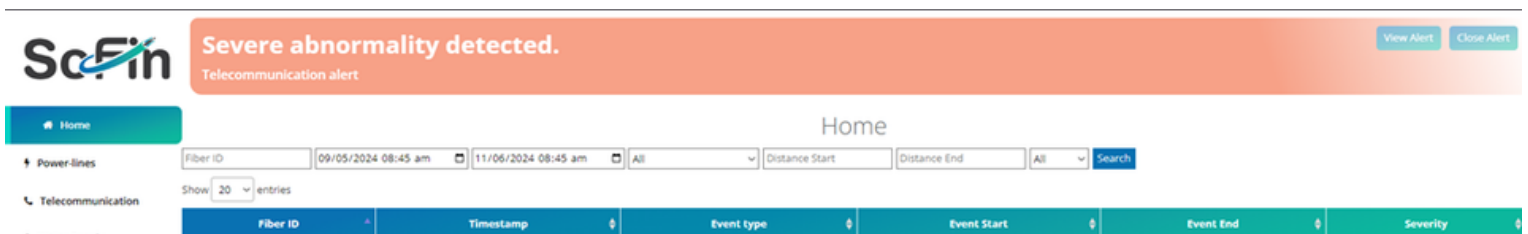

The SoFiN cloud platform to collect and store the data generated by the interrogator was developed. The data collected by the cloud platform and visualized using a simplistic information rich User Interface while also exposing REST Application Programming Interfaces.

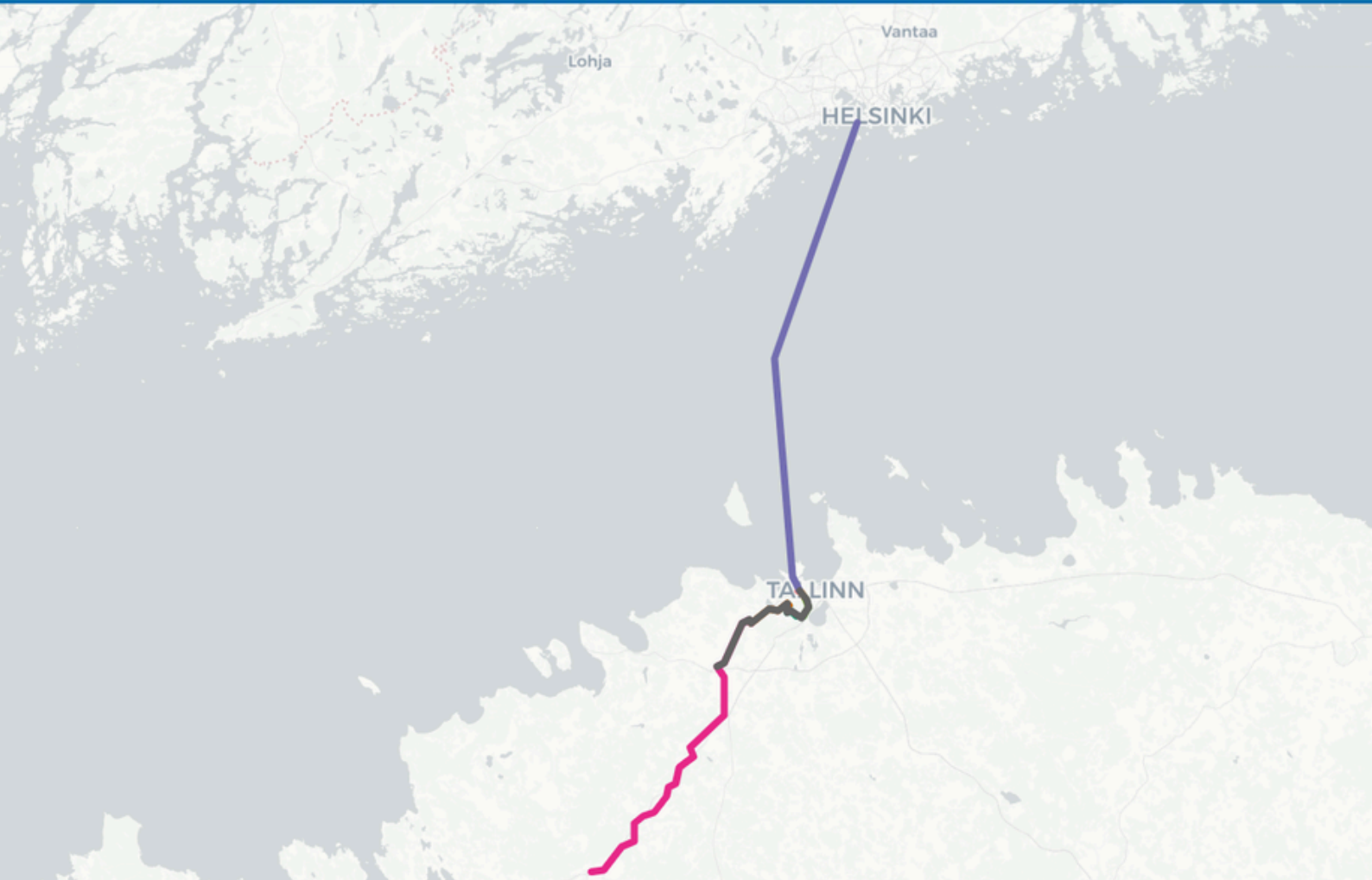

TELECOMMUNICATION INFRASTRUCTURE MONITORING

TELE2

Description

Field demo in a telecom network of partner Tele2 with three cable sections: subsea, underground, aerial

Key Findings



- Interrogation data successfully acquired
- Cloud connectivity and event monitoring confirmed
- The event classification algorithm validated



Funded by
the European Union

Project Funded by the European Union. Views and opinions expressed are however those of the author(s) only and do not necessarily reflect those of the European Union or HADEA. Neither the European Union nor the granting authority can be held responsible for them.

Project Facts

Start date: 01/12/2023

End Date: 30/11/2026

Funding: € 3 694 302,50

Partners: 8

Countries: 4

Grant Agreement ID: 101093015



SME/ Industrial Technology Developers



CY
Cooridnator



DK

Academia & Research Institutes



DK



DE

Applications / Use Case Owners



DE



DK



EE



CY



Funded by
the European Union

Project Funded by the European Union. Views and opinions expressed are however those of the author(s) only and do not necessarily reflect those of the European Union or HADEA. Neither the European Union nor the granting authority can be held responsible for them.

ScFin

THANK YOU

For more information, please contact:

Email: info@sofin-project.eu

Website: <https://sofin-project.eu>



<https://www.linkedin.com/company/sofin-project>



<https://www.facebook.com/sofinproject>



Funded by
the European Union

Project Funded by the European Union. Views and opinions expressed are however those of the author(s) only and do not necessarily reflect those of the European Union or HADEA. Neither the European Union nor the granting authority can be held responsible for them.